



**JAWAHARLAL NEHRU TECHNOLOGICAL UNIVERSITY KAKINADA**

Pithapuram Road, Kakinada-533003

Phone No. 0884 2300900, Fax: 0884-2300901

email: \_\_\_\_\_, rao703@yahoo.com

**AMENDMENT to Tender Notice No. JNTUK/ Furniture for  
SDC Labs /2017-18, Dated: 07-09-2017**

**Tender Notice No. JNTUK-/ Furniture for SDC Labs /2017-18,**

**Date: 13-09-2017**

Sealed quotations are invited from reputed Dealers/ Suppliers with make Godrej or Equivalent for the supply of the listed items. The detailed specifications, terms & Conditions for the items can be obtained in respect of items from the undersigned from 08/09/2017 between **11.00 AM to 5.00 PM** on payment of ₹. 500/- (**Non-Refundable**) in the form of Demand Draft payable at Kakinada in favor of **Registrar, JNTUK, Kakinada** drawn on any nationalized bank not earlier than date of this notification. The sealed quotations should reach the undersigned on or before **2.30 PM** on **21/09/2017**.

The University Authorities reserve the right to accept or reject any or all bids without assigning any reason whatsoever.

  
REGISTRAR  
**REGISTRAR**  
J.N.T. University Kakinada  
KAKINADA-533 003



**JAWAHARLAL NEHRU TECHNOLOGICAL UNIVERSITY KAKINADA**

**Pithapuram Road, Kakinada-533003**

**Phone No. 0884 2300900, Fax: 0884-2300901**

**email: , rao703@yahoo.com**

**Tender Notice No. JNTUK-/ Furniture for SDC Labs /2017-18,**

**Date: 13-09-2017**

### **TENDER SCHEDULE**

#### **GENERAL CONDITIONS:**

1. Please quote your lowest rates for each item described. The quotation should reach this office **on or before 21/09/2017 by 14:30 hrs.** Sealed covers should be submitted for the items super scribing as “**Tender No.**”, “**Date of opening:**”, Separate sealed cover should be submitted for each item. The sealed covers should be sent by the Registered Post or to be dropped in the sealed box provided in the office of the Principal. The tender will be **opened on 21/09/2017 at 15:00 hrs.** by the undersigned/his nominee in the presence of the committee members and available bidders or their representatives.
2. **E.M.D:** The tender documents should be submitted along with earnest money deposit **Rs.10,000/-** in the form of Demand Draft in favor of “**The Registrar, JNTUK, Kakinada**”. The Demand Draft pertaining to E.M.D. of unsuccessful party will be returned.
3. **PRICES:** The price should be F.O.R. destination inclusive of taxes, packing & forwarding charges, freight, delivery and installation charges. Items on rate contract, if any together with the terms and conditions may please be furnished.
4. **PAYMENT:** 100% payment will be made within a reasonable time only after the receipt of all items in good condition and installation as per given specifications and after testing for satisfactory working and on receipt of the company’s invoice with all Supporting vouchers such as copy of GST Registration certificate etc. **No advance will be paid in any case either in part or in full.**
5. **ACCEPTANCE:** It is not binding on the university/ institution to accept the lowest of the tenders. The university/ institution reserves the right to place orders for individual items with different bidders.
6. **SPECIFICATIONS:** Detailed specifications along with the description and make should be mentioned in the bid.
7. **Warranty/Guaranty:** Warranty/Guaranty period should be mentioned by the bidder.
8. **DELIVERY:** The period of delivery and completion of work at destination from date of placing orders is **FOUR WEEKS.**
9. **VALIDITY:** The quotations should be valid for at least 90 days.

10. The Institution reserves the right to cancel the tender without assigning any reason.
11. Those that purchased tender schedule officially by paying **Rs. 500/-** in the form of Demand Draft drawn in favor of Principal, JNTUK, University College of Engineering, payable at Kakinada are only eligible to participate in the tender. Those who have downloaded the tender schedule from the JNTUK website ([www.jntuk.edu.in](http://www.jntuk.edu.in)) should submit a separate DD for **Rs.500/-** along with the quotation.
12. This Institution being Government educational institution is exempted from payment of Central/State Excise Duty.
13. Since the college is Government institution whatever conditions are applicable to any Government institute shall be applicable even if not specified.
14. Any tender that is received after due date will not be accepted. The college is not responsible for any postal delay.
15. List of Major Customers should be provided.

Encl: Items with Description

  
**REGISTRAR**  
**REGISTRAR**  
**J.N.T. University Kakinada**  
**KAKINADA-533 003**

Specifications of  
**Furniture for SDC Lab**

**(T&O Lab, PDV Lab, Automation Lab, Mechatronics Lab, Electrical Lab  
& AM Lab)**



The following is the list of items required:

S.No	Item	Quantity
1	Standard Computer Table	60
2	Computer Chair	171
3	Executive Table	5
4	Table with front covering	18
5	Table without front covering	42

The detailed specifications are as follows:

### **1) Standard Computer Table:**

Specification: 18mm melamine table top with 4 sides 2mm PVC edging, the rest 15mm PU paper lamination

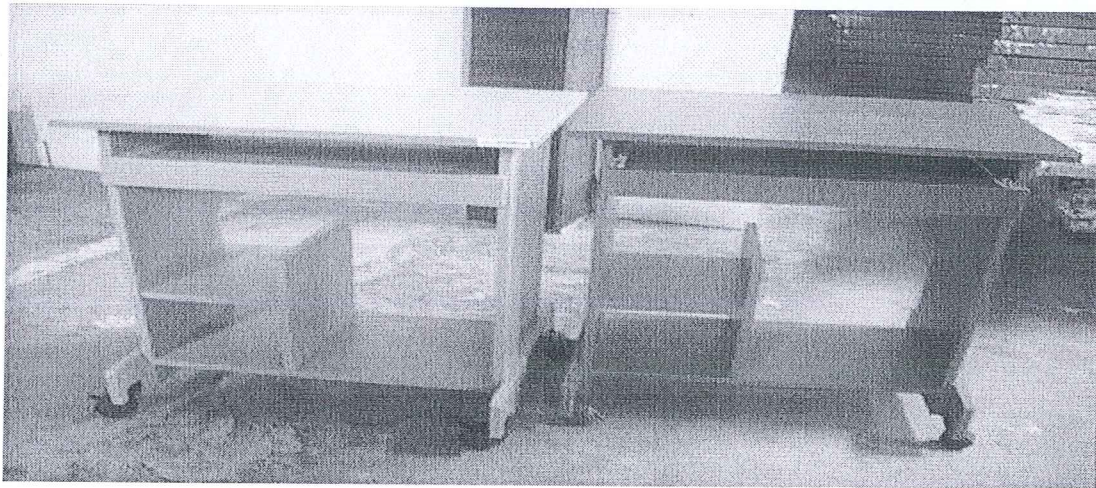

**Material:** Top 18 mm Melamine laminated Particle Board & rest 15 mm Paper laminated Particle board

**Hardware:** screw, KD Fittings, Castors

**Construction:** Knock down

**Load Bearing Capacity:** 30 Kgs.

**Packets:** 1 No.

**Finish:** Melamine laminated Top & rest Paper lamination (Colour : Honey or Cherry)

**Dimensions:** W 600 X D 450 X H 750

1) detailed specifications i.e. type of material, type of lamination, thickness of paper lamination used,

Top 18mm melamine face chipboard, others 15mm chipboard laminated with decorative paper

2) castor size, how many lockable and how many unlockable etc.

Castor size: 40mm x 45mm, 2 lockable, 2 unlockable

3) line drawing

See figure

4) carton dimensions, no. of cartons

Carton dimension: 706 x 523 x 101mm, 1 pc/ctn

5) gross and net weight of all cartons

G.W.: 17kgs, N.W. 16kgs

Make: Godrej or equivalent

## 2) COMPUTER CHAIR:

### PCH-5D02RX

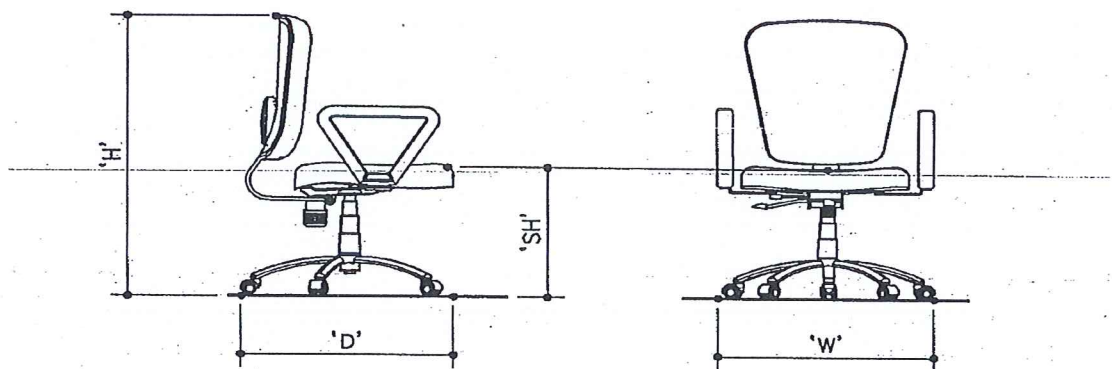

WIDTH (W): 65.0 CM.  
DEPTH (D): 65.0 CM.  
HEIGHT (H): 80.0-92.0 CM.  
SEAT HEIGHT (SH): 42.0-54.0 CM.

THESE DIMENSIONS ARE PRODUCT OUT TO OUT DIMENSIONS & VARIATIONS WITHIN  $\pm 1.0$  CM. ARE NORMAL

1) **SEAT/BACK ASSEMBLY:** The seat and back are made up of  $1.2 \pm 0.1$ cm thick hot pressed plywood measured as per QA method described in OCP-QLTA-P14-18 and upholstered with fabric (preferably blue color) and moulded Polyurethane foam with PVC lipping all around. The back foam is designed with contoured lumbar support for extra comfort.

\*PCH-5D02 (MID BACK) SIZE: 41.0cm(W) X 46.0cm (H)

\*PCH-5D02 SEAT ISIZE: 43.0cm(W) X 41.0cm (D)

2) **HIGH RESILIENCE (HR) POLYURETHANE FOAM:** The HR Polyurethane foam is moulded with density =  $45 \pm 2$  kgs /m<sup>3</sup> and Hardness load  $16 \pm 2$  kgf as per IS:7888 for 25% compression.

3) **ARMRESTS (for PCH -5D02R/5D13R):** The armset is made of black integral skin polyurethane with 50-70 Shore A hardness and reinforced with MS insert. The P.U. armrest is fixed to black powder coated (DFT 40-60 microns) armrest bracket made of  $0.5 \pm 0.05$  thk HR steel.

**4) PNEUMATIC HEIGHT ADJUSTMENT( For PCH-5D02):** The pneumatic height adjustment has an adjustment stroke of  $12.0 \pm 0.3\text{cm}$ .

**4A) PERMANENT CONTACT MECHANISM (for PCH-5D02):** The permanent contact mechanism is designed with the following features:

360° revolving type.

$14^\circ \pm 2^\circ$  maximum back-tilt only.

Upright position locking

Tilt tension adjustment

**5) TELESCOPIC BELOW ASSEMBLY (For PCH-5D02):** The below 3 piece telescopic type and injection moulded in black Polypropylene.

**6) PEDESTAL ASSEMBLY (For PCH-5D02):** The pedestal is fabricated from  $0.2 \pm 0.02\text{cm}$  thick HR sheet ( IS: DD 1079/ HR), powder coated (DFT 40-60 microns) and fitted with an injection moulded black Polypropylene hub cap and 5 nos. twin wheel castors. The pedestal is  $55 \pm 0.5\text{ cm}$  pitch-center dia. ( $65.0 \pm 1.0\text{cm}$  with castors).

**7) TWIN WHEEL CASTORS:** The twin wheel castors are injectionmoulded in Black Nylon.

**Make: Godrej or equivalent**

**3) EXECUTIVE TABLE:**

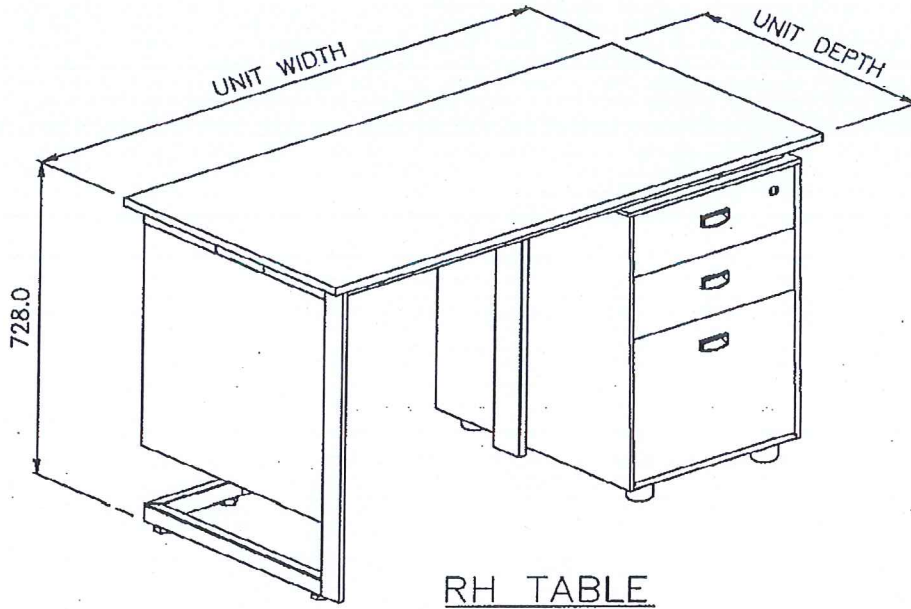

**Make: Godrej or equivalent**



Component		Specification	
Top	Worksurface	18mm thk. Pre Laminated Particle board (PLB) All work surface edges are duly sealed with 2mm thick PVC Edgebanding.	
Understructure	Modesty Panel	18mm thk. Pre Laminated Particle board (PLB) All work surface edges are duly sealed with 2mm thick PVC Edgebanding. Only offered in sizes 1500 and 1650 wide desk.	
	Rectangular Frame	Fabricated component in 1.2mm thick CRCA 'D' Grade as per IS:513. Finish: Epoxy Polyester Powder coated to thickness of 50 micron ( $\pm 10$ )	
	Leg	Fabricated component in 38mmx25mmx1.2mm thick MS ERW Tube (IS:7138), Finish: Epoxy Polyester Powder coated to thickness of 50 micron ( $\pm 10$ )	
	CPU Modesty	0.8mm thick 'D' Grade as per IS:513. Finish: Epoxy Polyester Powder coated to thickness of 50 micron ( $\pm 10$ )	
	Leveler glide for Leg	Nylon 6 & MS Bolt	
Wire-Management	Horizontal Wire Carrier	0.7mm thick CRCA 'D' Grade as per IS:513. Finish: Epoxy Polyester Powder coated to thickness of 50 micron ( $\pm 10$ )	
	Vertical Wire Carrier	0.8mm thick CRCA 'D' Grade as per IS:513. Finish: Epoxy Polyester Powder coated to thickness of 50 micron ( $\pm 10$ )	
Storage	Pedestal	Drawer Configuration/ Product size/ Styling	<ul style="list-style-type: none"> <li>Box-Box-File : 355.5(w) x 559(d) x 670#(h)</li> <li>Enclosing</li> </ul> #-Including Leveler.
		Construction & Material	<ul style="list-style-type: none"> <li>Welded Assembled</li> <li>Shell -0.6mm Thk CRCA as per IS-513.</li> <li>Drawer Tray &amp; back- 0.5mm Thk. CRCA as per IS-513</li> <li>Drawer Front- 0.6mm Thk. CRCA as per IS-513</li> </ul>
		Locking	<ul style="list-style-type: none"> <li>Cam Lock.</li> </ul>
		Leveler	<ul style="list-style-type: none"> <li>Plastic M8 leveler mounted below Body Shell.</li> </ul>
		Handle	<ul style="list-style-type: none"> <li>Injection moulded Polypropylene</li> </ul>
		Finish	<ul style="list-style-type: none"> <li>Epoxy Polyester Powder coated to the thickness of 50 microns (<math>\pm 10</math>)</li> </ul>

**4) TABLE WITH FRONT COVERING:**

Desk with one drawer & HDU attachment  
Size 1350 x 750 x 750 mm

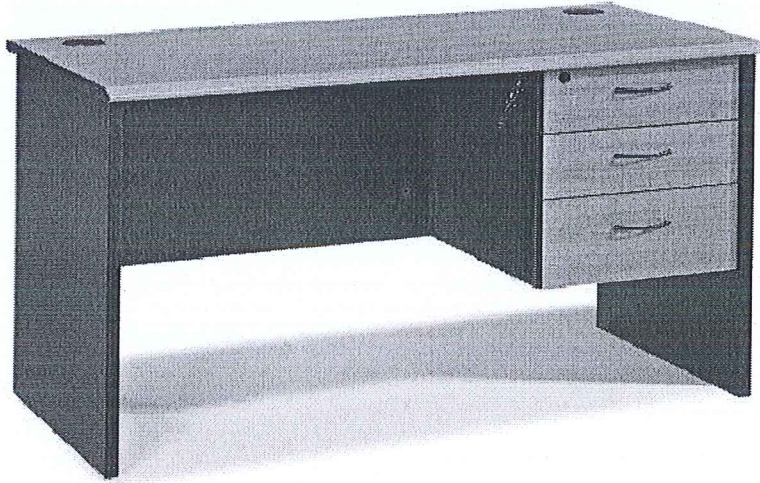

**Material** Prelaminated Particle Board with 18mm thick table top and 15mm thick understructure covered with PVC Lipping.

**Locking** Locking facility should be available for top drawer/s only. Attractive colour handles for all drawers.

**Colour** Preferably Beech colour (see picture attached)

**Make:** Godrej or equivalent

**5) TABLE WITHOUT FRONT COVERING:**

**Model:**

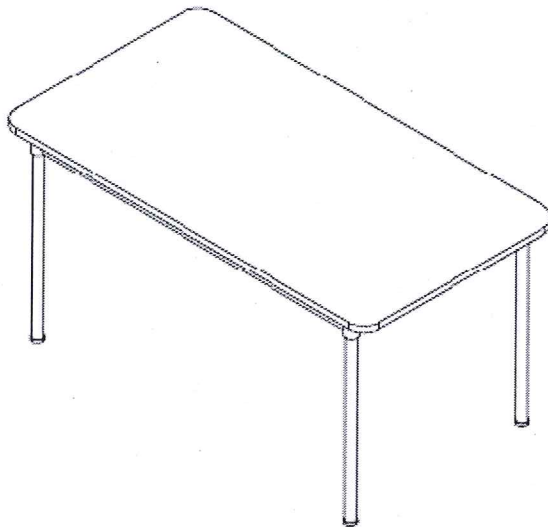

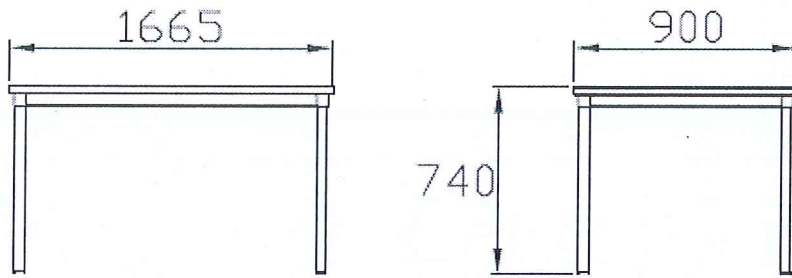

**Top:- NOVOPAN DECORATIVE LAMINATE**

**Leg:- M.S.TUBE 38 DIA X 16 BG=PAINTED**

#	Elements	Specifications
Top	Worktop	25 mm Thick PLB Tops with 2mm Thick PVC Edge Beading
Understructure	C – Frames	1.6 mm thick M.S C-Frame Supporting the Top.
	Legs	Dia. 38.1 x 1.6 mm thick M.S ERW tube.

**Make: Godrej or equivalent**